

UPLIFTING COMPANY

AUTOP **STENHOJ**



Maestro 2.32 & 2.35 NxT

Electro-mechanical 2-post lift
with 3.2 & 3.5 t capacity

NxT Generation

NxT Generation - Surface-mounted lifts

The highlights of the Maestro 2.32 & 2.35 NxT:

- Low minimum height
- Stable, welded columns
- Cold-rolled spindles for a particularly long service life
- Universal lifting area

The premium solution: universal, durable, strong

When it comes to a high level, you should be sure to pay attention to the details.

Maestro 2.32 & 2.35 NxT

The 2-post lifts of the Maestro 2.xx series impress with their premium construction.

They come with **extremely stable and welded columns**.

Smooth running behaviour is ensured by the **roller-bearing carriage**.

The **cold-rolled spindle** guarantees a **particularly long service life**.

The columns are asymmetrically positioned, i.e. vehicles can be positioned far to the rear, which ensures an **optimal door opening angle**.

Of course, the Maestro 2.32 & 2.35 NxT also have door stop protection to prevent damage during entry and exit.

The **swivel arms are extremely flat** and thus ensure a low minimum height. The **internal arm locking system** with strong 360° interlocking protects against moisture and dirt.

Recommendations / Approvals Maestro 2.35 NxT:

- BMW / Mini
- Mercedes Benz
- Volvo



Maestro 2.32 & 2.35 NxT

Technical data

	Maestro 2.32 NxT	Maestro 2.35 NxT
Lifting capacity	3200 kg	3500 kg
Stroke length	1900 mm	1900 mm
Working height	F: 1985 - 2015 mm CF: 1990 - 2145 mm CF-08: 1995 - 2155 mm	F: 1987 - 2012 mm CF: 1988 - 2125 mm CF-08: 1995 - 2155 mm
Lifting/lowering time	~ 40 sec.	~ 35 sec.
Motor	2 x 2.8 kW	2 x 2.8 kW
Voltage	2x 230/400V - 50 Hz - 25 A	2x 230/400V - 50 Hz - 25 A

Arm superstructure

Lifting pad included in the delivery.	F: 85 - 115 mm CF: 90 - 245 mm CF-08: 95 - 255 mm	F: 87 - 112 mm CF: 88 - 255 mm CF-08: 95 - 255 mm
Total height post	2713 mm	2713 mm
Total height incl. portal	4050/4350 mm	4350/5050 mm
Drive-through width	2100 - 2300 mm	2195 mm DT/DT 2445 mm DT/ST, ST/ST
Width between posts	2380 - 2580 mm	2509 mm DT/DT 2759 mm DT/ST, ST/ST
Total width - outer edges base plates	3120 - 3320 mm	3250 mm DT/DT 3500 mm DT/ST, ST/ST
Total width - outer edges posts	2920 - 3120 mm	3050 mm DT/DT 3300 mm DT/ST, ST/ST
Arm length front, min.-max.	F ST: 540 - 850 mm CF ST: 580 - 890 mm CF-08 ST: 555 - 840 mm	Standard: DT/ST F Premium DT: 586 - 1189 mm CF Premium DT: 692 - 1144 mm CF-08 Premium DT: 555 - 1100 mm
Arm length rear, min.-max.	F ST: 900 - 1425 mm CF ST: 935 - 1425 mm CF-08 ST: 920 - 1415 mm	Standard: DT/ST F Premium ST: 927 - 1551 mm CF Premium ST: 1046 - 1670 mm CF-08 Premium ST: 925 - 1550 mm

Maestro 2.32 & 2.35 NxT

Standard colour:

- Arms: RAL 3020
- Posts: RAL 7016

Optional extras:

- Available with different portal heights, alternatively inground kit
- LED-lighting set
- Energy set with compressed air and socket-outlet
- Set of expansion bolts
- Extra control unit for second column
- Large program of extra pads, depending on type of vehicle

Variants:

- Available for different voltages
- F = flex pad
- CF = combiflex pad
- CF-08 = combiflex-08 pad

Maestro 2.35 NxT

DT/ST = double telescopic short arms in front / single telescopic long arms in rear

DT/DT = double telescopic short arms in front and rear

ST/ST = single telescopic long arms in front and rear

Maestro 2.32 NxT

ST/ST = single telescopic long arms in front and rear



Maestro 2.35 NxT

Maestro 2.32 & 2.35 NxT

Electro-mechanical 2-post lift with 3.2 t capacity

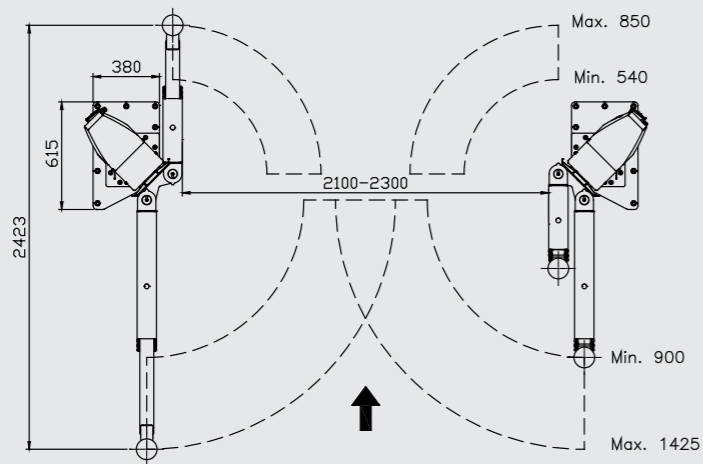
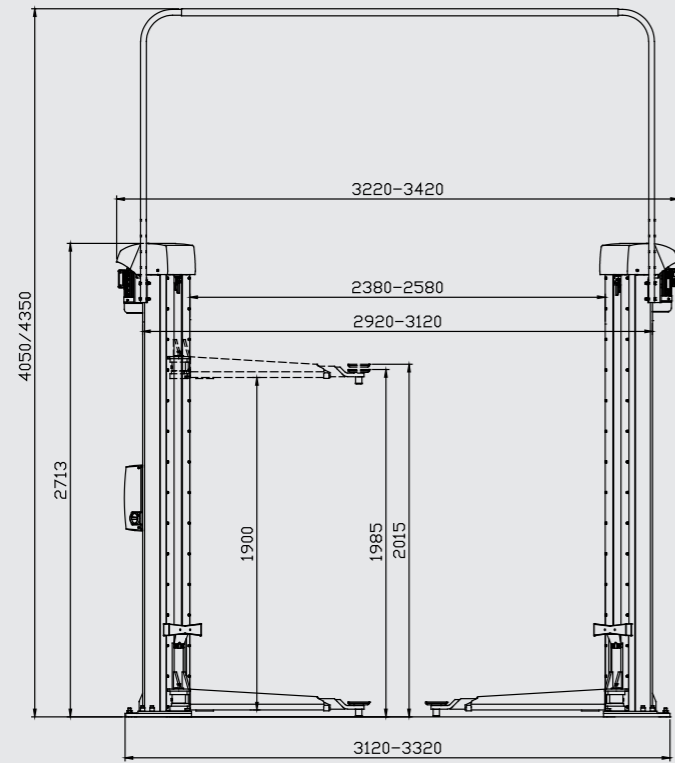

Short arm

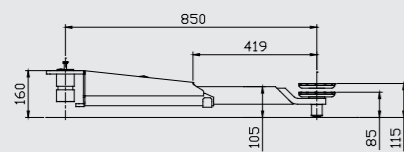

Long arm

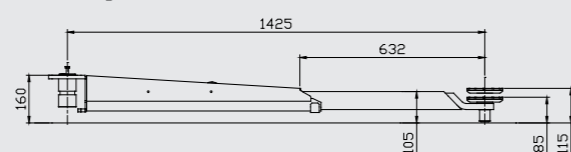

Maestro 2.32 & 2.35 NxT

Electro-mechanical 2-post lift with 3.5 t capacity

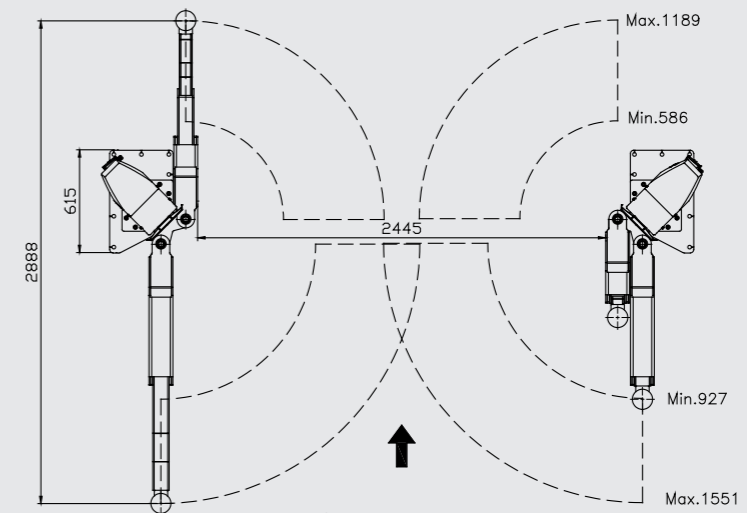
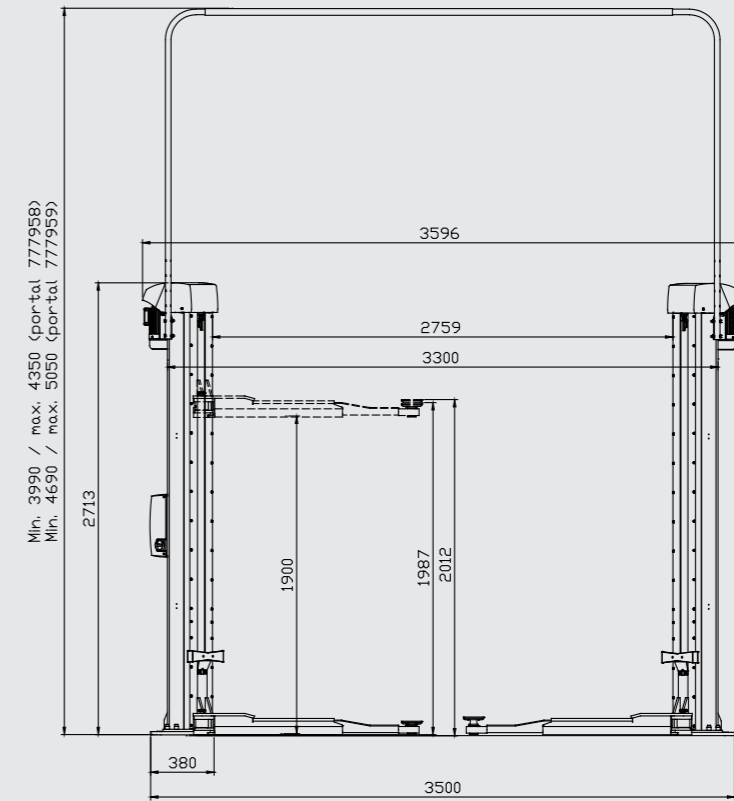

Short arm

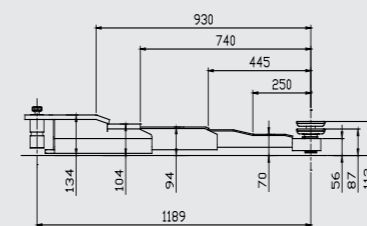

Long arm

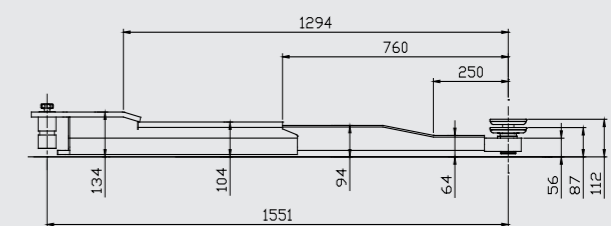

Maestro 2.32 & 2.35 NxT

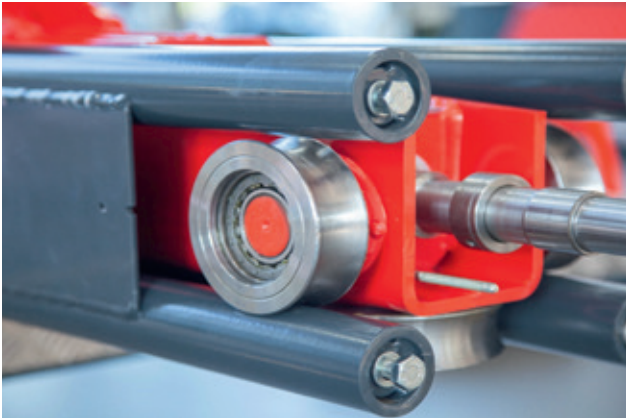

And even more highlights: Surface-mounted lifts with that certain something!

With the **NxT Generation surface-mounted lifts** from AUTOPSTENHOJ you will experience quality at the highest level! We have made the best even better for you!

NxT Generation surface-mounted lifts Maestro 2.xx: strong, form-fitting components for smooth running and minimal wear brought together to create the strongest and slimmest 2-post lift on the market.

The columns of the **Maestro 2.xx NxT series lifts** are made of 4 strong tubes welded together, which at the same time creates a **slim appearance** and yet forms **the strongest column on the market**.

The positive convex-concave relationship between the steel rollers and the columns ensures particularly **smooth running**.

Furthermore, **this design reduces resistance and thus wear** to an absolute minimum.

The **Maestro 2.xx NxT lifts** are the strongest and slimmest on the market.

They offer **excellent access to the vehicle** and ensure **fast and reliable work**, for many years to come.

NxT Generation Maestro: universal, durable, strong

