

AUTOP

ERKSKUNDENDIENST

Maestro 2.50 & 2.60 NxT

Electro-mechanical 2-post lift
with 5.0 & 6.0 t capacity

NxT Generation

NxT Generation - Surface-mounted lifts

When it comes to a high level, you should be sure to pay attention to the details.

Maestro 2.50 & 2.60 NxT

The 2-post lifts of the Maestro 2.xx series impress with their premium construction.

They come with **extremely stable and welded columns**.

Smooth running behaviour is ensured by the **roller-bearing carriage**.

The **cold-rolled spindle** guarantees a **particularly long service life**.

The welded and symmetrically positioned columns are ideal for the **safe lifting of large and heavy vehicles up to a maximum of 5 or 6 tonnes**, even with difficult lifting points.

The **universal lifting range** allows all vehicles to be lifted safely, from small cars to long-wheelbase vans.

Thanks to the flat swivel arm design and the newly designed base plate, even lifting low vehicles is a simple matter, as the swivel arms reach the ground.

Also suitable for the safe lifting of electric vehicles.



The highlights of the Maestro 2.50 & 2.60 NxT:

- Slimmest and strongest column on the market
- Low space requirement and optimum access to the vehicle
- Flat arm design due to newly designed base plate
- Arm design suitable for wheel support devices
- Universal lifting range

Perfectly lifted, even when the going gets tough!

Maestro 2.50 & 2.60 NxT

Technical data

	Maestro 2.50 NxT	Maestro 2.60 NxT
Lifting capacity	5000 kg	6000 kg
Stroke length	1900 mm	1900 mm
Working height	F DT/DT: 2000 - 2045 mm	F DT/DT: 2000 - 2045 mm
Lifting/lowering time	~ 55 sec.	~ 55 sec.
Motor	2 x 2,8 kW	2 x 2,8 kW
Voltage	3x230/400 V-50Hz - 35/25A	3x230/400 V-50Hz - 35/25A

Arm superstructure

Lifting pad included in the delivery	F 770505: 30-60 mm	F 770505: 30-60 mm
Min. height	110 mm	110 mm
Total height post	2912 mm	2912 mm
Total height incl. portal	4885 - 5245 mm	4885 - 5245 mm
Drive-through width	2910 - 3110 mm	2910 - 3110 mm
Width between posts	3238 - 3438 mm	3238 - 3438 mm
Total width - outer edges base plates	4000 - 4200 mm	4000 - 4200 mm
Total width - outer edges posts	3627 - 3827 mm	3627 - 3827 mm
Arm length front, min-max.	F DT/DT: 906 - 1926 mm	F DT/DT: 906 - 1926 mm
Arm length rear, min-max.	F DT/DT: 906 - 1926 mm	F DT/DT: 906 - 1926 mm

Maestro 2.50 & 2.60 NxT

Standard colour:

- Arms: RAL 3020
- Posts: RAL 7016

Optional extras:

- Available with different portal heights, alternatively inground kit
- LED-lighting set
- Energy set with compressed air and socket-outlet
- Set of expansion bolts
- Extra control unit for second column
- Wheel support devices
- Large program of extra pads, depending on type of vehicle

Variants:

- F = flex pad
- Available for different voltages
- DT / DT = double telescopic arms in front and rear
- 50 mm Ø hole in arms for lifting pads



Maestro 2.60 NxT

Maestro 2.50 NxT

Electro-mechanical 2-post lift with 5.0 t capacity

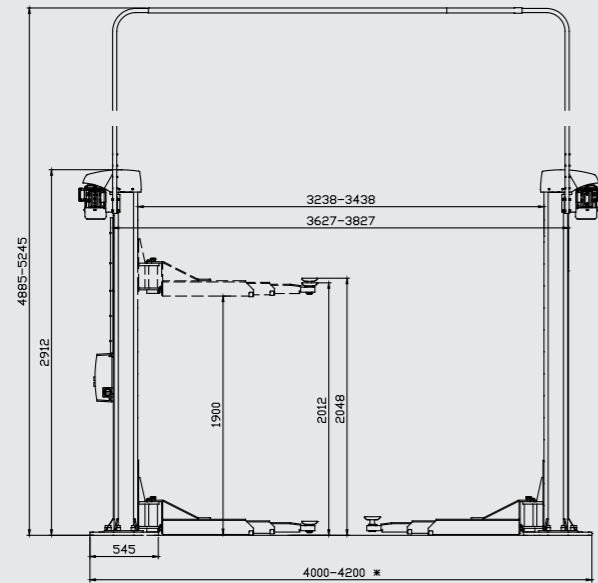

4000 mm: recommended for lifting transporter
4200 mm: recommended for universal lifting area,
more focus on passenger cars

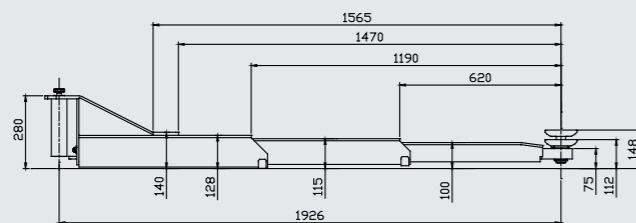
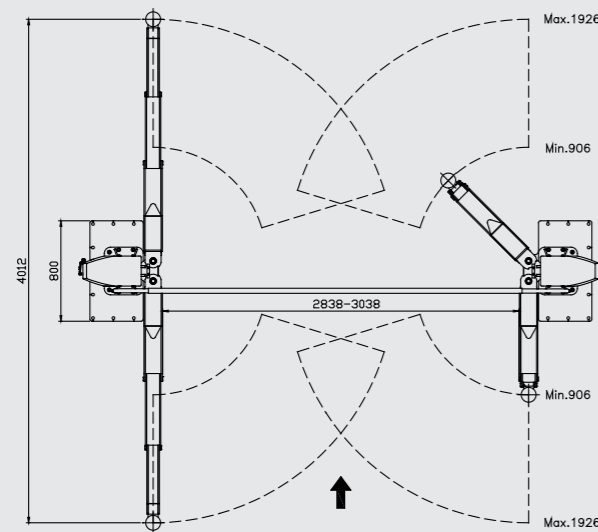

Illustrations are not binding and optional. Under reserve of dimensional, constructional and technical modifications! Validity 01/2024

Maestro 2.60 NxT

Electro-mechanical 2-post lift with 6.0 t capacity

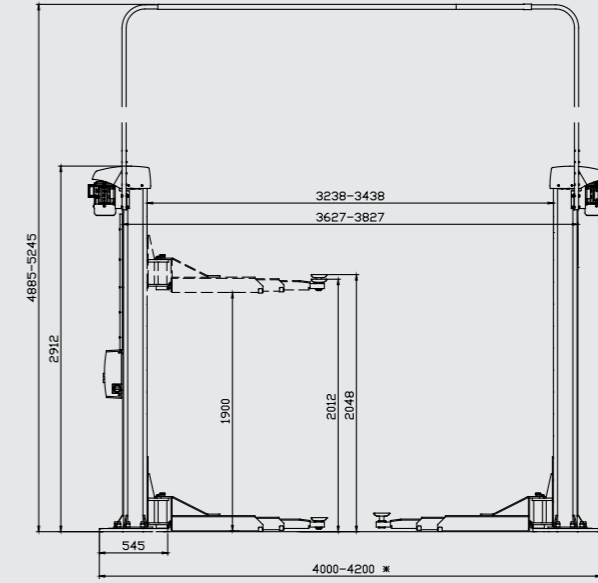

4000 mm: recommended for lifting transporter
4200 mm: recommended for universal lifting area,
more focus on passenger cars

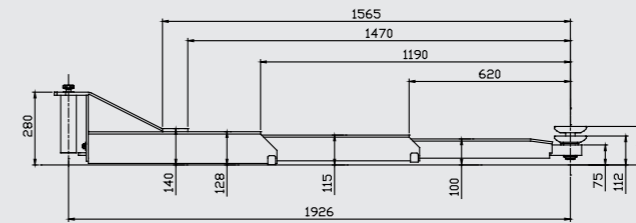
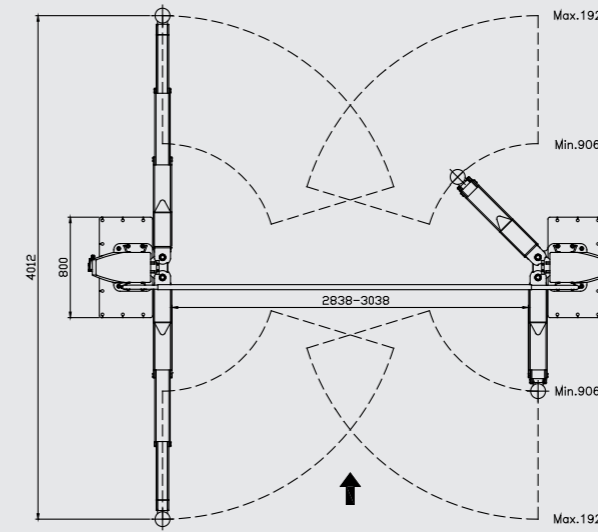

Illustrations are not binding and optional. Under reserve of dimensional, constructional and technical modifications! Validity 01/2024

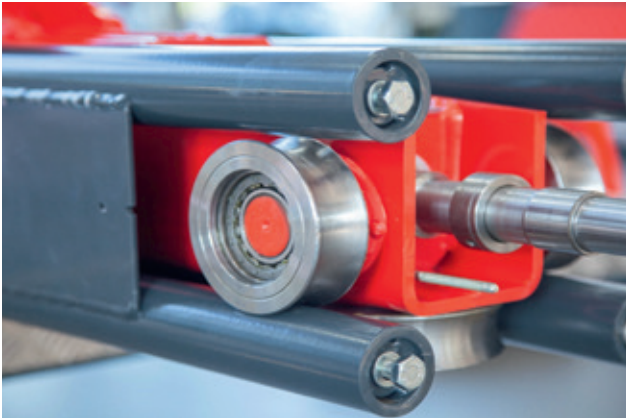

And even more highlights: Surface-mounted lifts with that certain something!

With the **NxT Generation surface-mounted lifts** from AUTOPSTENHOJ you will experience quality at the highest level! We have made the best even better for you!

NxT Generation surface-mounted lifts Maestro 2.xx: strong, form-fitting components for smooth running and minimal wear brought together to create the strongest and slimmest 2-post lift on the market.

The columns of the **Maestro 2.xx NxT series lifts** are made of 4 strong tubes welded together, which at the same time creates a **slim appearance** and yet forms **the strongest column on the market**.

The positive convex-concave relationship between the steel rollers and the columns ensures particularly **smooth running**.

Furthermore, **this design reduces resistance and thus wear** to an absolute minimum.

The **Maestro 2.xx NxT lifts** are the strongest and slimmest on the market.

They offer **excellent access to the vehicle** and ensure **fast and reliable work**, for many years to come.

NxT Generation Maestro: universal, durable, strong

